

ROOF REPLACEMENT AND SKYLIGHT REPLACEMENT

ENDERBY CITY HALL

ENDERBY, BC.

SPECIFICATIONS

OKANOGAN ROOF CONSULT 2000

INVITATION TO TENDER

Project- **ENDERBY CITY HALL**
619 Cliff Ave
Enderby, BC, V0E1E0

Description **Removal of existing cedar assembly roof system to substrate, walls and flashings, appliances, and replacement also includes a new sky light on low slope (sbs) styrene butadene styrene roof assembly.**

Obtain Documents **Tender documents will be available at the site meeting.**

Site Tour *Non-mandatory site meeting may be scheduled upon request by the bidder(s)*

Bonding Requirements **None**

Tender Closing **Sealed tenders must be received prior to _____ 2018**
4:00 pm August 15,

Address and Submit Tenders to:

Via Mail: PO Box 400 619 Cliff Ave., Enderby, BC. V0E

Att: Kurt Inglis, Planner, & Deputy Corporate Officer

Via Courier: If tender is forwarded by courier, please use Purolator Express

Via Fax: Fax submittals are not acceptable

It is the bidder's responsibility to ensure timely receipt of tenders.

Tender Conditions:

Tenders must remain valid for (30) thirty days from the tender close. The Owner reserves the right to reject any or all tenders.

<u>Bidding and Contract Requirements</u>		<u>No.of pages</u>
Invitation to Tender		1
Table of Contents		1
List of Consultants		1
Section 00100	Instruction to Bidders	1
Section 00300	Construction Tender Forms	2
 <u>General requirements</u>		
	Site Visit Form	1
Section 01060	Project Procedures	3
Section 01065	Cleaning	1
 <u>Thermal and Moisture Protection</u>		
Section 07400	Performed Roofing and Sheet Metal	1
Drawings	A1,A2 A3 A4 (four drawings)	
Complete Specification		23
Payment schedule for Roof Replacement and Skylight replacement		1

Enderby City Hall List of Consultants

Roof Replacement & Skylight Replacement

Owner City of Enderby
619 Cliff Ave.
Enderby, BC, V0E1V0

Contact

Mr. Kirk Ingils
Planner and Deputy Corporate Officer
PO Box 400 619 Cliff Ave.
Enderby, BC V0E1V0 Telephone (250) 838 7230

Consultant

Mr. Jay N. Morgan
Okanogan Roof Consult 2000
119 12560 West Side Rd.
Vernon, BC, V1H1S9
Jay N. Morgan Phone (250) 938 5989
Email roofconsult2000@yahoo.ca

1.0 TENDER CALL

- .1 Bidders must be Roofing Contractors licensed to carry on business in British Columbia who employ qualified roofing trades people.

2.0 RECEIPTS OF TENDERS

- .1 The receipt of tenders must be submitted and delivered in a sealed envelope marked "Tender for Roof Replacement."

3.0 UNACCEPTABLE TENDERS

- .1 Tenders not submitted on the accompanying Construction Tender Form will not be considered.
- .2 Tender forms and enclosures, which are incomplete or improperly prepared, may be declared as unacceptable.
- .3 Tenders by fax shall not be considered.

4.0 QUERIES

- .1 All queries regarding the Bidding Documents shall be directed to:

Okanogan Roof Consult 2000

119- 12560 West Side Rd.

Vernon, BC.V1H 1S9

Attention: Jay Morgan

Ph (250) 938-5989

5.0 ADDENDA

.1 Bidders may, during the tendering period, be advised by Addendum of any alteration to the Bidding Documents. All such changes will become part of the contract Documents and the affects shall be included in the Contract Price,

.2 Bidders finding discrepancies within, or omissions from the drawings or specifications, or other documentation or having any doubt as to the meaning or intent of any portion thereof, shall immediately contact the consultant who shall send written instructions to all Bidders. Neither the Owners nor the consultant shall be responsible for oral instructions. Bidders shall not rely on oral instruction from The Consultant or owner UNLESS they have been confirmed in writing by the Consultant.

6.0 EXAMINATION OF PROJECT

.1 The Bidder shall examine the Project and familiarize himself with local conditions, access and anything else that may have an impact upon cost. Progress or performance of the work, including any local by-laws including any government regulations. Claims for additional cost shall not be entertained with respect to conditions, which would have been ascertained by an inspection of the above site prior to Bid closing date.

7.0 ACCEPTABLE EQUIVALENT SYSTEMS

.1 Equivalent systems, other than those provided for within the specifications for this project, must be submitted within 10 (ten) days prior to the closing date for approval. The proposed system if acceptable shall not result in any additional costing to the Owner. The change shall be for the sole benefit of the Owners.

.2 Application for acceptance of "alternate" or "equal " status by a supplier implies a realisation that he must adjust his material and/or methods and/or systems as necessary to be fully compatable and interface with all other aspects of the Contract.

Work Description

Roof Replacement & Skylight Replacement

City Hall Enderby

619 Cliff Ave. Enderby, BC V0E 1V0

The tender is submitted

Name of Tender

Telephone

Owner

City of Enderby

City Hall/ 619 Cliff Ave.

Enderby, BC. V0E 1V0

We,

Name of Tenderer

Of

Address

having examined the tender documents as listed in the Table of Contents and addenda

No 1 to No _____ inclusive, all as issued by Okanogan Roof Consult2000 and having visited and examined the project and subject roofs, hereby offer to enter into a contract to perform the work required by the tender documents for the stipulated price of:

Contract Price \$ _____

GST \$ _____

Total Amount \$ _____

Signature of Tenderer _____

Enderby City Hall

Site Visit

Roof Replacement & Skylight Replacement

Page 1 of 1

Proof of Mandatory Site Visit Form

This form shall be completed, signed by the Contractor and verified by the representative of the Owner in order to ensure the Contractor has visited the site, and familiarized himself with the job site conditions, reviewed the current conditions and verified the full scope of the work. The Consultant or Owner will not be responsible for any verbal instructions conveyed during the scheduled site visit, unless confirmed in writing and issued by addenda.

Project Viewed

Date of Site Inspection

Contractor's Name

Contractor's Address

Contractor's Representative's Signature

Contractor's Representative's Position with Firm

The above-named Contractor agrees to include this Proof of Site Visit form as part of his tender documentation submission to be considered by the Owner on the above noted project.

1.0 General

- .1 This contract shall be:**
- Roof Replacement & Skylight Replacement**
 - City Hall**
 - Enderby BC, V0E 1V0**

1.1 Codes & Standards

.1 Conform to the latest issue of codes, standards specified, all relevant and applicable codes, ordinances and by-laws as amended and revised on date of receipt of bids.

1.2 Safety

.1 N.B If a torch is lit upon the roof, without exception a fully charged ABC extinguisher shall be within 20 (twenty) horizontal feet of the applicator. It is imperative an extinguisher is present for each lit torch .No exceptions.under any circumstances.

CONTRACTOR SHALL HAVE A FULLY CHARGED ABC EXTINGUISHER WITHIN 20 HORIZONTAL FT. OF EVERY LIT TORCH ... NO EXCEPTIONS Min 10 #

NO DIRECT TORCHING TO SUBSTRATE

.2 Observe and enforce all construction safety measures required by the National Building Codes of Canada Labour (Safety) code and municipal statutes and or by-laws.

.3 In the event of conflict between any provisions of the above authorities, the most stringent provision shall be applicable.

.4 The contractor shall restrict his activities only to the areas in which the work is being performed.

1.3 Inspection Notices

.1 The contractor shall provide a minimum of 48 hours notice to the Consultant prior to commencement of project. The failure to provide such notification shall render the contractor responsible, and a no cost to the owner liable to remove or uncover work as may be necessary to permit inspection.

1.4 Protection of work and property

.1 Protect the property under this contract and adjacent private and public property from damage during the performance of the work. All damages caused by the Contractor or the Contractor's staff at his expense shall rectify any damage at no cost to Owner.

.2 Adequately protect all existing work to remain. Any work damaged due to failure to properly provide protection is to be removed and replaced or repaired at the contractors expense with no cost to the Owner.

.3 All materials shall be stored off the roof surface, tarped with commercial tarpaulins and tied securely, Any materials susceptible to moisture shall be removed from the site at the Contractors expense and replaced with new

1.5 Temporary Facilities& Utilities

.1 Temporary facilities shall be provided by the Contractor

Porta Poti / Power generator if no service available from within City Hall

1.6 Regulatory Requirements

.1 This work shall comply with all regulatory authorities

.2 Obtain all required permits and pay all fees.

1.7 Existing Features

.1 The location of existing features has been determined from existing records, but is not guaranteed. The location of such features is to be the sole responsibility of the Contractor.

1.8 Insurance

.1 The successful tenderer shall provide proof that he is covered by Public Liability and property Damage Insurance to at least (5,000,000.00) Five Million dollars, and include the City of Enderby as a named insured.

1.8 continued

And all deductibles are paid for by the Roofing Contractor. Proof of coverage may be in the form of a copy of the policy or a document from the Insurance provider. The Contractor's insurance shall be such that torch applied installations are an integral portion of their policy and no limits to the percentage of torch applied systems per annum. And the Contractor acknowledges this contract falls within the percentage allowable under the terms of their policy.

.2 The Contractor shall save and hold harmless the Owner, its officers, Agents, Servants, and employees. From and against any and all suits or claims alleging damage or injury (including death) to any person or property that may occur or may alleged to have occurred in the course of the performance of this contract, whether such claim shall be made by an employee of the Contractor or by third person whether or not it shall be claimed that the alleged damage or injury (including death) was caused through willful or negligent act or omission of the Contractor, its officers, servants, agents, or employees, and at its own expense shall defend any and all such actions and pay all legal costs and other expenses arising there from.

.3 A minimum of \$5,000,000.00 of public liability and property damage insurance shall be carried on all automotive equipment.

1.1 Description

.1 Execute cleaning during the process of removal and at the completion of the Works and as herein specified.

1.2 Disposal Requirements

.1 Conduct cleaning and disposal operations to comply with codes, ordinances, regulations and all anti-pollution laws. House keeping to be undertaken on an ongoing basis daily.

.2 Dispose of all rubbish, debris and waste materials at periodic intervals, away from the site and in a legal manner at an approved dumpsite. The responsibility and cost of this work shall be born by the Contractor and included within the contract price.

1.3 Materials

.1 Use only those cleaning materials, which will not create health hazards and / or contamination (air borne or otherwise). To property and which will not damage any surfaces being cleaned.

1.4 During Construction

.1 Execute routine cleaning and/ or as may be directed by the Consultant, to keep the Work, the site, and the adjacent areas free from accumulation of debris, waste materials and or wind blown debris resulting from the construction operation and/ or material storage and delivery.

Part 1-General

1.1 Scope of work

.1 The work includes, but is not necessarily limited to supply of all labour and equipment necessary for the removal and disposal of all existing roof systems, insulation and metal flashings (to be reinstalled) as necessary to comply with the project specifications.

.01 26 gage pre-finished , "w" centre crimped valley flashing min 24" & drip edge.

.02 Self adhering sbs (styrene butadene styrene) eave protection.(Armourgard)

.03 Roofgard-cool grey synthetic underlayment.

.04 IKO Cambridge architectural shingles A/R /equivalent starter shingles

.05 7/16 osb or plywood.

.06 1.25 " nails.

.07 Externally baffled ridge venting /low profile AF 50 where applicable.

.2 Carefully remove as required the following materials and equipment and store and reinstall using qualified trades people.

.3 Remove any deleted or residual roof top equipment and dispose of in a lawful manner in a designated and approved dumping facility. This contractor shall include within the tendered price all associated costs for tipping fees and labour required to do so.

1.2 Areas of Work

.1 All roof areas with shakes inclusive of eyebrows & lower canopies. App. 50 sq.

.2 SBS roof assembly remove and replace skylight and all interfacing materials

inclusive of curb to achieve a min 8 inches above completed roof assembly & counterflashings.

1.3 Existing Systems

.1 Shake system, felt, app. 50 sq. plus starters hips ridges. App 4/12 slope

.2 SBS system/low slope membranes/insulation Commercial skylight/curb/flashings.

1.4 Reference Standards

.1 Conform to the appropriate CSA, CGSB and ASTM Standards for the materials used in the roofing systems specified

.2 RCABC Manual / Mfg. Criteria

1.5 Performance Requirements

.1 Provide for positive drainage to gutter systems.

.2 Compatibility of all materials interfacing with project.

1.6 Quality Assurance

.1 Qualifications

.01 The work people engaged by the Contractor for this work shall be competent tradespeople and be thoroughly informed with the materials and the procedures to install.

1.7 PRODUCT DELIVERY, STORAGE & HANDLING

.1 Deliver and store all materials in their original containers in undamaged condition, sealed with labels intact, having manufacturers' name, brand, weight, CSA and other references to accepted standards clearly shown. No damaged material to be accepted.

.2 Any materials that become damaged due to inclement weather, or improper handling or any other causes, such material shall be rejected and replaced with new at no cost to Owner.

1.8 Quality Control

.1 Inspections to be carried out by Okanogan Roof Consult2000. Cost of inspection services to be paid by Owner. The Owner reserves the right to inspect the work site or materials at any time.

.2 All materials roofing or otherwise, to be installed by a qualified trades person. The roofing crew to have a minimum of one fully qualified roofer with past experience applying the products specified.

1.9 Submittals

.1 If installation details vary from specifications, submit shop drawings showing details.

1.10 Project Conditions

.1 The building spaces directly under the roof areas covered by this specification may be used for concurrent and ongoing activities. The operations shall not interrupted unless prior written approval is received from the owner.

.2 Environmental Requirements:

- .1 No installation work to be performed during inclement or rainy weather.**

.3 Protection:

- .1 Exercise care to avoid marks or smears on the exposed finishes. Costs to rectify for damages and smears shall be the sole responsibility of the Contractor.**
- .4 Provide, maintain and remove on completion, barriers, hoardings and warning safety signs in work areas and for the protection of work people.**

Explosive or other impact-actuated fasteners shall not be used to fasten metal flashings. On concrete or block substrates, use screw/plug fasteners with washers in pre-drilled holes.

3.5 Completion

Upon completion of the work the following:

- .1 All drains are not blocked. Obtain services of professional drainage company to clear any blockage or restriction.**
- .2 Remove all waste and construction material from site.**
- .3 repair any damage to building or grounds.**
- .4 Clean grounds to original status prior to commencement of re-roofing.**
- .5 Compatible mastic shall be applied to the base of all appliances. That may be in the areas where S.B.S membranes are installed.**
- .6 Provide maintain and remove upon completion, barriers, signage, and hoardings in work areas used for the protection of Owner's employees and public during installation procedures.**

4.0 Warranties

.1 Contractor shall provide Owners with Mfg. Warranty data that explicitly defines warranty criteria, and any exclusions that may affect Mfg. Warranty. Any cost associated with the warranty is included within the Contract.

.2 Guarantee

.1 The Contractor shall provide a five (5) year written guarantee on Company letter head The guarantee shall cover the faithful performance of the blocking, installation of all interfacing components associated with the roof replacement and skylight replacement, inclusive of flashings.

A1 OF 4

Valley flashing ONE layer of galvanized or pre-painted sheet metal (min. 26 Gg.) not less than 600 mm (24") wide
or

Granulated SBS modified bitumen membrane, min. 3.7 mm thick, 390 mm wide, centred on valley, fastened 450 mm (18") o/c at 25 mm (1") from edges

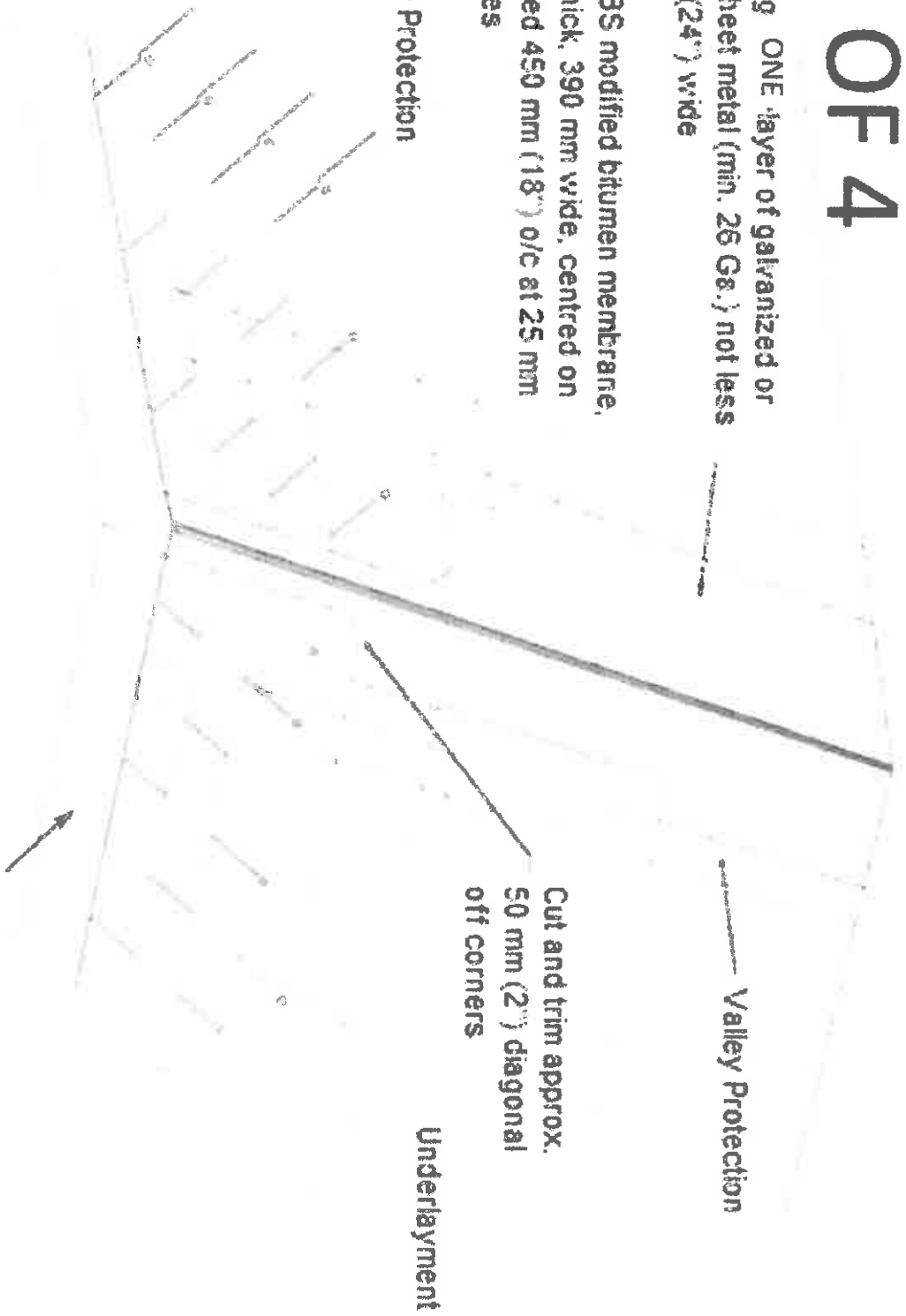

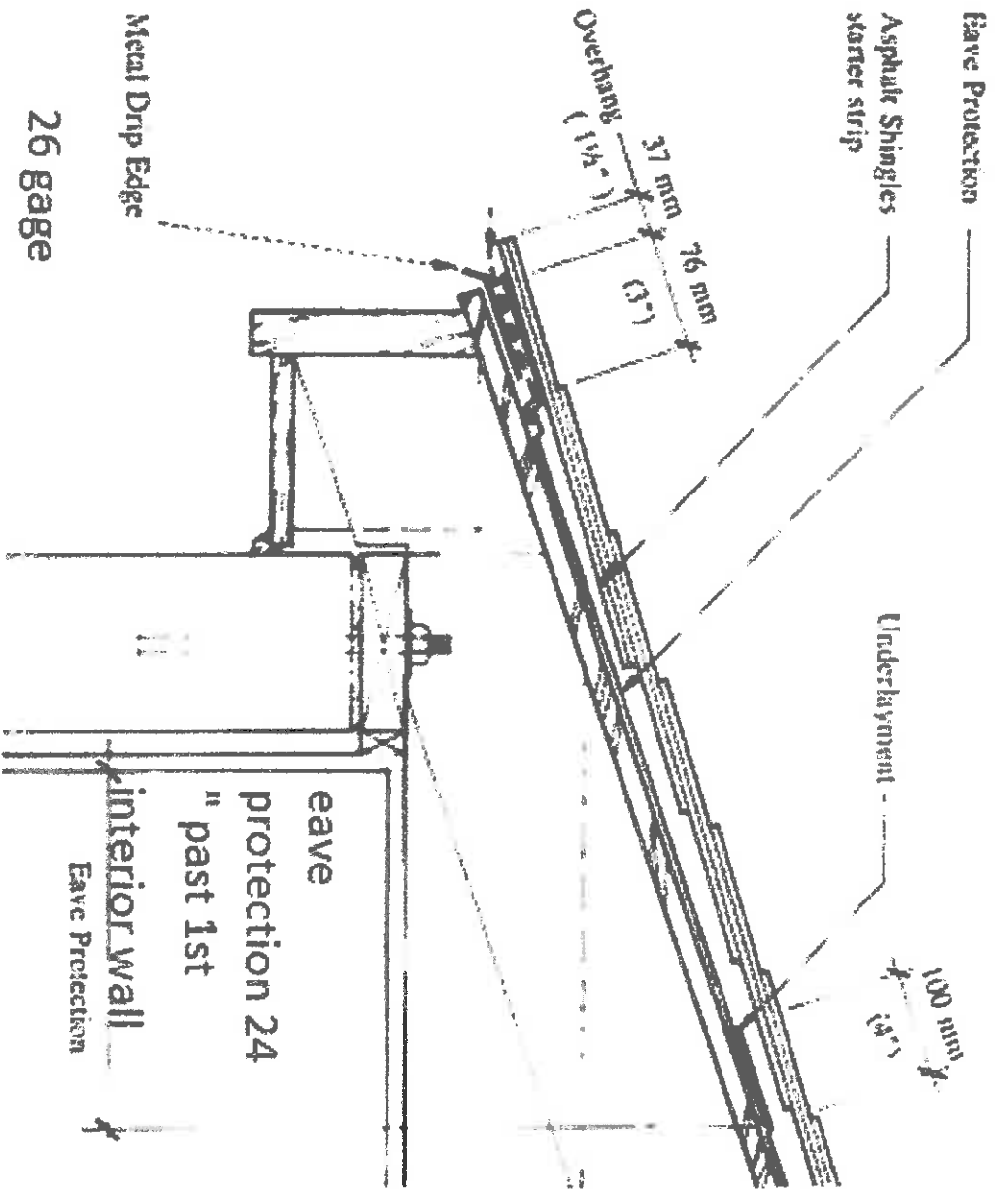

A 2 OF 4

A 3 OF 4

Install dividers @ 20%
to slope of roof.

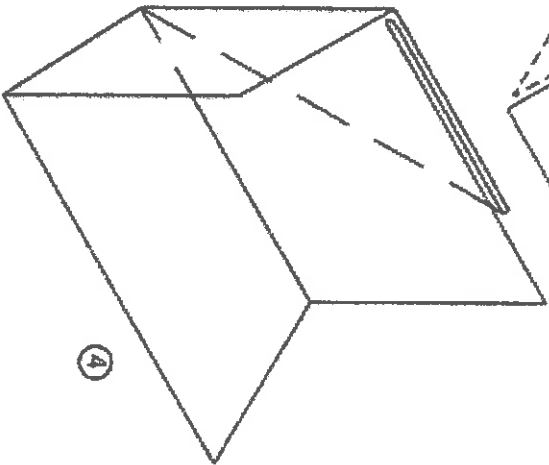
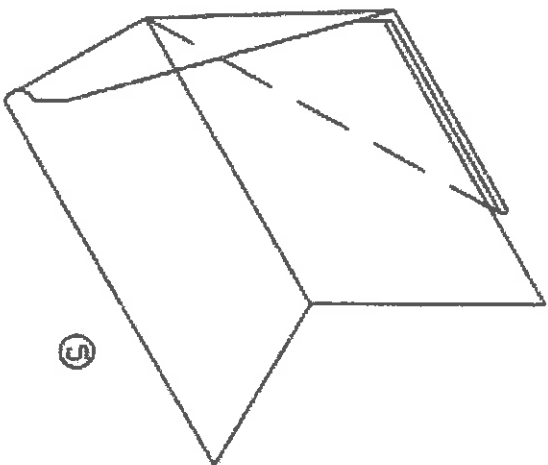
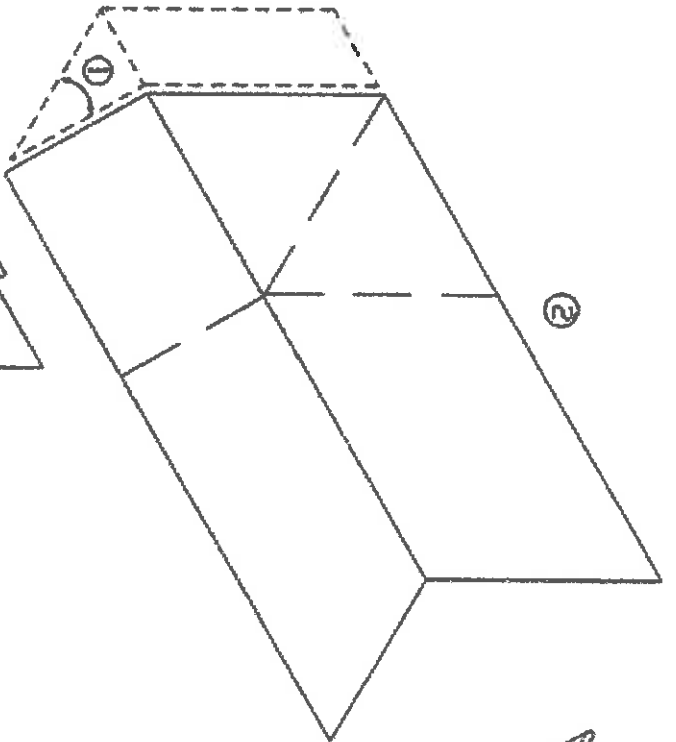
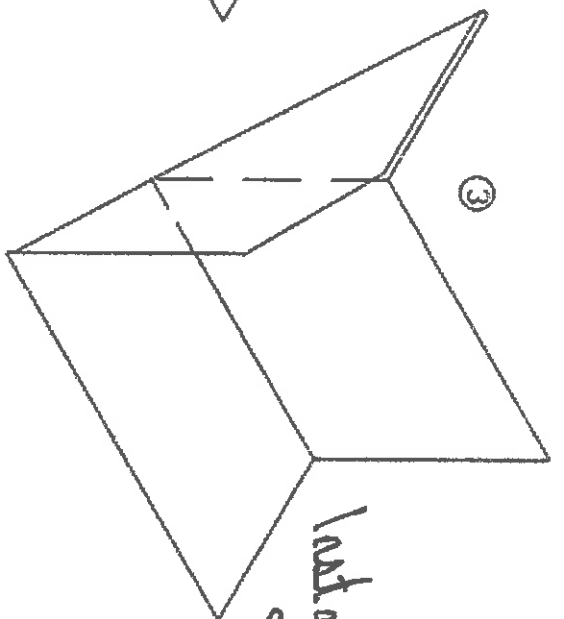

A 4 OF 4
A LOW SLOPE SBS
B SHAKE STEEP
ROOFING
skylight



G.E.
Topographical
view/ low slope/
pitched / shake

PAYMENT SCHEDULE FOR ENDERBY CITY HALL

The draws for re-roofing shall be based on the following criteria

A 10 percent hold back on each segment till completion of project.

Verification of payment of labour, written verification is acceptable.

Final payment shall be released upon notarized verification of all disbursements.

Hold back shall be for a period of 60 days from receipt of notarized statement indicating all bills have been payed .The final payment shall be held in trust until all documentation has been completed and any deficiencies have been dealt with to the satisfaction of the Owner and or owner's representatives.

First request for draw may be submitted upon commencement of project and loading of materials.

First draw not to exceed 30% of total project value.

Subsequent draws shall be based on completion of roof assembly and rectifying any deficiencies prior to the submission of invoice.